

Screw-In Casters / Side Mount Brackets for Casters / Dedicated Wrenches for Screw-In Casters

Low Profile

■ **Features:** Low installation height with low gravity center that allows users to use them for conveying heavy objects.



Type		D	Wheel	Main Body	Bearing
Screw-In	Screw-In with Stopper		Material	Surface Treatment	(Wheel Bearing)
CHJFN	CHJFNS	50A	Special Reinforced Plastic (Black)	SPHC	Trivalent Chromate
		50B			
		65A			
		65B			
		75A			
CHJNM	CHJNSM	50A	MC Nylon (Blue)	SPHC	Trivalent Chromate
		50B			
		65A			
		65B			
		75A			
75B					

Swivel
CHJFN
CHJNM

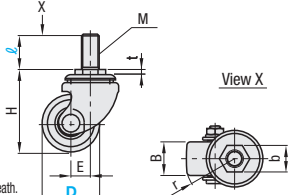

Swivel with Stopper
CHJFNS
CHJNSM

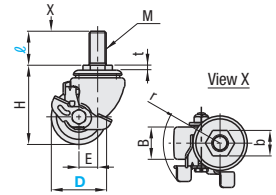

Ⓜ For dedicated wrenches, see underneath. Ⓜ r indicates the swivel radius of the wheel and turning radius of the pedal.

Main Body	Part Number		ℓ (Thread Length)	M (Coarse)	H	B	b	t	E	r	Allowable Load (N)		Mass (g)	Unit Price	
	Type	D									Plastic	MC Nylon		CHJFN / CHJFNS (Plastic)	CHJNM / CHJNSM (MC Nylon)
Swivel Screw-In	CHJFN (Plastic) CHJNM (MC Nylon)	*50A	40	16	74	28	23	7.9	25	51	1000	1000	390		
		*50B		20							430				
		65A		16							620				
		65B		20							650				
		75A		16							760				
75B	20	790													
Swivel Screw-In with Stopper	CHJFNS (Plastic) CHJNSM (MC Nylon)	*50A	80	16	74	28	23	7.9	25	65	1000	1000	430		
		*50B		20							470				
		65A		16							680				
		65B		20							710				
		75A		16							830				
75B	20	860													

Ⓜ D50A and D50B have no bearings in the wheels. Ⓜ To improve the swiveling performance, the dust-proof ring shape of the products with D Dimension 65A / 65B / 75A / 75B will be revised since April 1, 2014.

Ordering Example: Part Number - ℓ
CHJNM65A - 40

Side Mount Brackets for Casters

CPHM

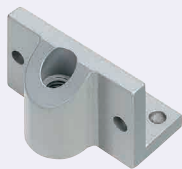

RoHS 10

Ⓜ Material: ADC12
Ⓜ Surface Treatment: Baked Paint (Silver)

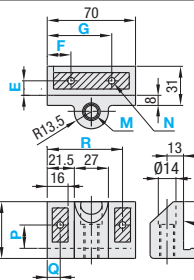

Hole Type	Through Hole
Code	N
Shape	
Machining Specifications	Dimension
	Nominal Dia.
	N 5 6
	d 6 7

Ⓜ Please specify through-hole locations within .
Ⓜ Type for Aluminum Extrusions, see P.840.

Part Number	N (Through Hole)	Drilling Position 0.5mm Increment						Mass (g)	Unit Price		
		M (Coarse)	Selection	E	F	G	P			Q	R
CPHM	5	10	6	8~15	8~28	42~62	8~29	7~13	57~63	135	
		12									

Ordering Example: Part Number - N - E - F - G - P - Q - R
CPHM10 - 5 - E12 - F25.5 - G46.5 - P28 - Q13 - R58

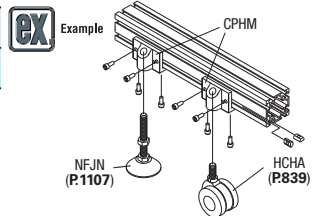

Dedicated Wrenches for Screw-In Casters

PFSP



Ⓜ Material: SPCC

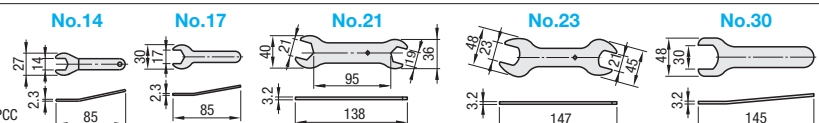

Part Number	Mass (g)	Unit Price
14	18	
17	27	
21	58	
23	61	
30	73	

Ordering Example: Part Number
PFSP14