

SA1形

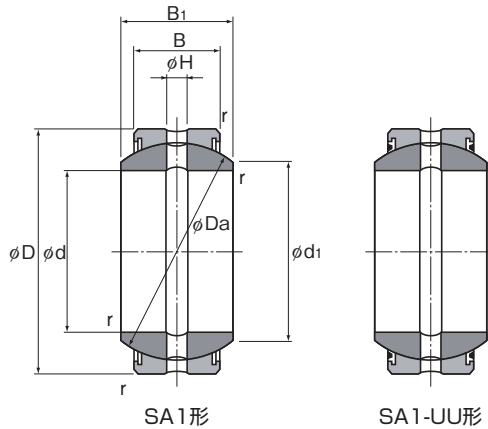

単位:mm

呼び形番		主要寸法								基本定格荷重		質量
標準形	シール形	内径	外径	外輪幅	内輪幅					C	C ₀	kg
		d	D	B	B ₁	d ₁	Da	H	r	kN	kN	
SA1 12	SA1 12UU	12	22	7	10	15	18	1.5	0.3	2.94	74.1	0.017
SA1 15	SA1 15UU	15	26	9	12	18.4	22	2.5	0.3	4.7	117	0.032
SA1 17	SA1 17UU	17	30	10	14	20.7	25	2.5	0.3	5.88	147	0.049
SA1 20	SA1 20UU	20	35	12	16	24.2	29	2.5	0.3	8.23	205	0.065
SA1 25	SA1 25UU	25	42	16	20	29.3	35.5	4	0.3	13.3	334	0.115
SA1 30	SA1 30UU	30	47	18	22	34.2	40.7	4	0.3	17.3	431	0.16
SA1 35	SA1 35UU	35	55	20	25	39.8	47	4	1	22.1	553	0.258
SA1 40	SA1 40UU	40	62	22	28	45	53	4	1	27.5	686	0.315
SA1 45	SA1 45UU	45	68	25	32	50.8	60	6	1	35.3	882	0.413
SA1 50	SA1 50UU	50	75	28	35	56	66	6	1	43.5	1090	0.56
SA1 60	SA1 60UU	60	90	36	44	66.8	80	6	1.5	67.7	1700	1.1
SA1 70	SA1 70UU	70	105	40	49	77.9	92	8	1.5	86.6	2170	1.54