

# PHC-0.6, 1.2, 2.5, 5, 10, 20R

Model	Static friction torque(Nm)	Rated voltage(DC-V)	Power consumption at 75°C(W)	Mass(kg)
PHC-0.6R	6	24	22.5	4.2
PHC-1.2R	12	24	23	5.7
PHC-2.5R	25	24	30	10
PHC-5R	50	24	54	17
PHC-10R	100	24	52.8	43
PHC-20R	200	24	66	70

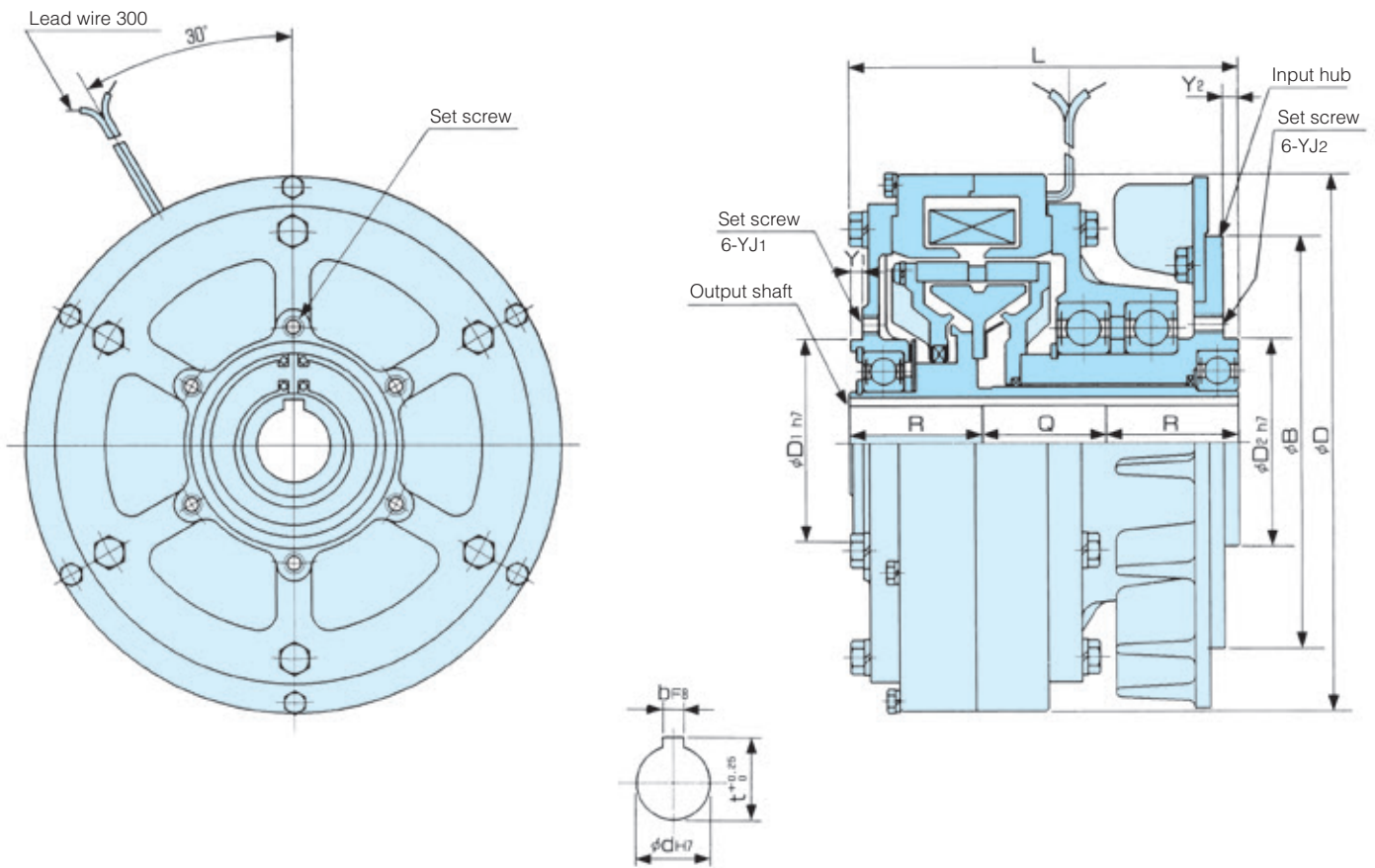

Model	Diameter direction				Shaft direction					Attachment				Shaft hole		
	B	D	D2	D1	L	Q	R	Y1	Y2	YJ1		YJ2		d	b	t
										P.C.D	Tap	P.C.D	Tap			
POC-0.6R	89	134	50	50	93	42	25.5	4	4	60	M4×6	60	M4×6	12	4	13.5
POC-1.2R	89	152	45	70	96	46	25	4	4	80	M4×8	55	M5×6	15	5	17
POC-2.5R	140	182	70	70	132	42	45	4	5	80	M6×9	80	M6×10	25	7	28
POC-5R	165	219	87	87	148	68	40	4	4	102	M8×10	102	M8×10	35	10	38.5
POC-10R	190	290	105	110	183.5	63.5	60	4	6	140	M8×10	120	M10×13	45	12	48.5
POC-20R	220	335	130	130	222	69	75	4	9	150	M10×13.5	150	M10×13.5	55	15	60