

CB01 Series

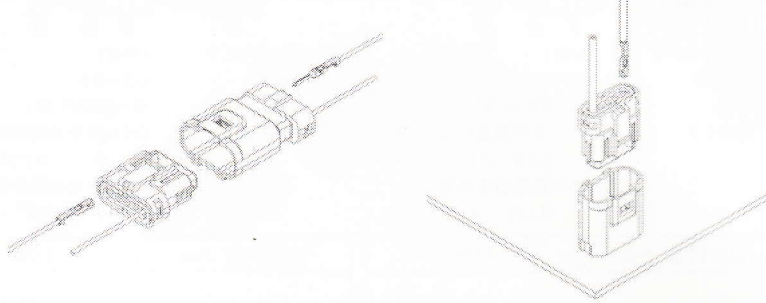
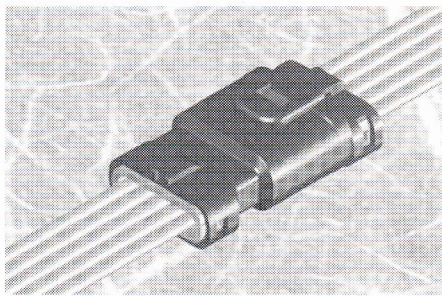

特長 FEATURES

- 2.5mmピッチの防水コネクタです。小型で、かつ、高信頼性を保持した製品でコネクタに内蔵したワイヤーシールに端子を押し込みリテーナで保持して防水性を確保しています。中継・基板タイプの2種類があり、基板タイプは逆挿入防止ボス付です。
- 用途は防水性能が必要な電化製品一般で、風呂の電化製品、トイレ洗浄器、給湯機器、業務用冷蔵庫、洗濯機、浄水器、屋外モータなどがあります。
- As being a waterproof small-sized connector of 2.5 mm pitch, which products has high-reliability. Without requiring crimping of wire seal one each wire, it's perfect way for waterproof that terminals crimped on wire are simply inserted into the wire seal inside the housing and push retainer into. Available in two types including one for repeating and the other for poting substrate. The latter is provided with a boss serving to prevent inverse insertion.
- Applications are included electric appliances for bath, toilet syringes, hot-water suppliers, washing machines, water purifiers, outdoor moters, industrial refrigerators.

仕様 SPECIFICATIONS

1	極数 Poles	2, 3, 5P
2	ピッチ Pitch	2.5mm
3	定格電圧 Rated Voltage	250V
4	定格電流 Rated Current	3A max.
5	耐電圧 Withstand Voltage	AC1000V r.m.s.
6	接触抵抗 Contact Resistance	15mΩ max.
7	絶縁抵抗 Insulation Resistance	1000MΩ min./DC500V
8	使用温度範囲 Temperature Range	-40°C ~ +105°C
9	保護等級 IP Code	IP67
10	適用基板厚 PCB Thickness	1.6mm

材質 MATERIALS

ハウジング Housing	PBT (UL94V-0)
端子 Terminal	リン青銅/錫めっき Phosphor Bronze/Tin plating
ピンブロック Pin-Block	ガラス入りPBT (UL94V-0) PBT with glass (UL94V-0) 黄銅/錫めっき Brass/Tin plating
ワイヤー・ハウジングシール Wire・Housing seal	シリコンゴム Silicone Rubber

組立レイアウト ASSEMBLY LAYOUT

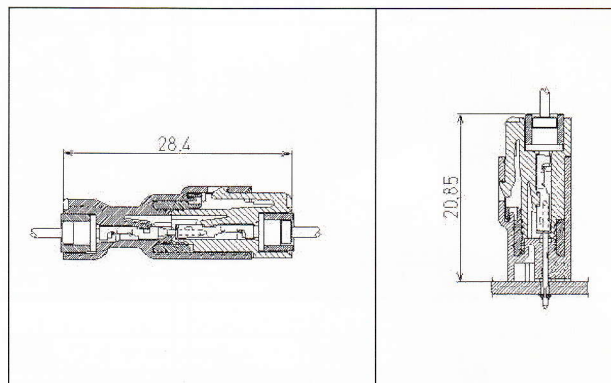

ワイヤーシール WIRE SEAL

ワイヤーシール Wire seal	被覆外径 Ins. dia.	色 Color	適用端子 Applicable Terminal
01	φ1.0~1.30	黄色 Yellow	CB01C5-010A CB01C6-010A
02	φ1.30~1.70	橙色 Orange	CB01C5-020A CB01C6-020A

《端子》

品番 Part No.	ワイヤレンジ Wire range	被覆外径 Ins. dia	数量/リール Pcs/Reel	備考 Remarks
CB01C5-010A	AWG#22~28	φ1.6 max.	8,000×5 R	M
CB01C6-010A			10,000×6 R	F
CB01C5-020A	AWG#20~22	φ1.7 max.	8,000×5 R	M
CB01C6-020A			8,000×6 R	F

端子 TERMINALS

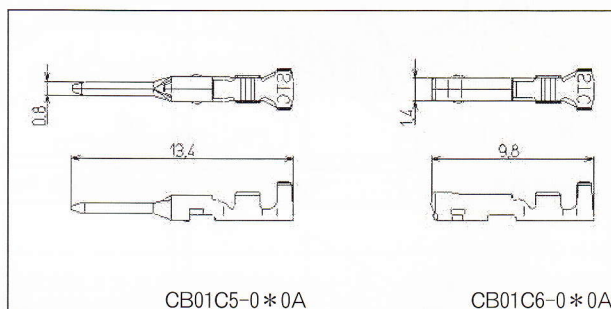

- ★ CB01コネクタにはワイヤーシール、ハウジングシール、リテーナがセットされています。
- ★ 防水栓のCB01E0-01N0もあります。
- ★ 潜水状態での使用には対応していません。
- ★ Wire seals, housing seal and retainers are already assembled inside of CB01 connector.
- ★ Water proofing cap (P/N=CB01E0-01N0) are available to cover the hole of wire seal.
- ★ Submerged in water is not available.