

エルボタイプ

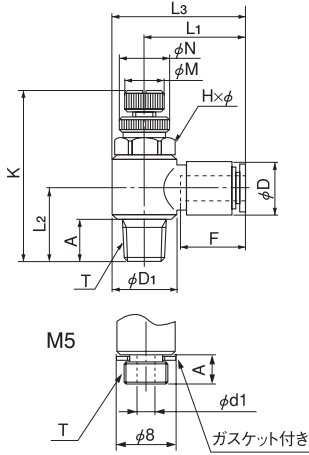

●ミリサイズ

品番	適用チューブ外径 (mm)	Tねじサイズ (M,R)	L <sub>1</sub> (mm)	L <sub>2</sub> (mm)	L <sub>3</sub> (mm)	K		A (mm)	Fチューブ挿入長さ (mm)	H×φ二面幅 (mm)	N (mm)	M (mm)	D (mm)	D <sub>1</sub> (mm)	質量 (g)
						全開 (mm)	全閉 (mm)								
ASC4-M5-O	4	M5×0.8	18.0	10.1	22.8	28.6	25.8	3.4	13.5	8.0×9.0	8.0	5.0	9.8	9.6	8.0
ASC4-M5-I	4	M5×0.8	18.0	10.1	22.8	28.6	25.8	3.4	13.5	8.0×9.0	8.0	5.0	9.8	9.6	8.0
ASC4-R1/8-O	4	R1/8	20.1	13.7	27.2	36.0	31.0	7.3	13.5	12.0×13.5	11.0	8.0	9.8	14.2	19.0
ASC4-R1/8-I	4	R1/8	20.1	13.7	27.2	36.0	31.0	7.3	13.5	12.0×13.5	11.0	8.0	9.8	14.2	19.0
ASC6-M5-O	6	M5×0.8	20.3	10.1	25.1	28.6	25.8	3.4	15.0	8.0×9.0	8.0	5.0	12.6	9.6	9.0
ASC6-M5-I	6	M5×0.8	20.3	10.1	25.1	28.6	25.8	3.4	15.0	8.0×9.0	8.0	5.0	12.6	9.6	9.0
ASC6-R1/8-O	6	R1/8	21.8	13.7	28.9	36.0	31.0	7.3	15.0	12.0×13.5	11.0	8.0	12.6	14.2	20.0
ASC6-R1/8-I	6	R1/8	21.8	13.7	28.9	36.0	31.0	7.3	15.0	12.0×13.5	11.0	8.0	12.6	14.2	20.0
ASC6-R1/4-O	6	R1/4	23.6	18.2	32.9	40.3	35.3	10.8	15.0	14.0×15.8	13.0	10.0	12.6	18.5	33.0
ASC6-R1/4-I	6	R1/4	23.6	18.2	32.9	40.3	35.3	10.8	15.0	14.0×15.8	13.0	10.0	12.6	18.5	33.0
ASC8-R1/8-O	8	R1/8	26.6	13.7	33.7	36.0	31.0	7.3	16.0	12.0×13.5	11.0	8.0	14.6	14.2	21.0
ASC8-R1/8-I	8	R1/8	26.6	13.7	33.7	36.0	31.0	7.3	16.0	12.0×13.5	11.0	8.0	14.6	14.2	21.0
ASC8-R1/4-O	8	R1/4	24.9	18.2	34.1	40.3	35.3	10.8	16.0	14.0×15.8	13.0	10.0	14.6	18.5	34.0
ASC8-R1/4-I	8	R1/4	24.9	18.2	34.1	40.3	35.3	10.8	16.0	14.0×15.8	13.0	10.0	14.6	18.5	34.0
ASC8-R3/8-O	8	R3/8	26.9	19.9	38.2	46.3	41.3	11.1	16.0	19.0×21.0	16.0	13.0	14.6	22.6	62.0
ASC8-R3/8-I	8	R3/8	26.9	19.9	38.2	46.3	41.3	11.1	16.0	19.0×21.0	16.0	13.0	14.6	22.6	62.0
ASC10-R1/8-O	10	R1/8	30.4	13.7	37.5	36.0	31.0	7.3	19.0	12.0×13.5	11.0	8.0	17.5	14.2	23.0
ASC10-R1/8-I	10	R1/8	30.4	13.7	37.5	36.0	31.0	7.3	19.0	12.0×13.5	11.0	8.0	17.5	14.2	23.0
ASC10-R1/4-O	10	R1/4	31.5	18.2	40.7	40.3	35.3	10.8	19.0	14.0×15.8	13.0	10.0	17.5	18.5	37.0
ASC10-R1/4-I	10	R1/4	31.5	18.2	40.7	40.3	35.3	10.8	19.0	14.0×15.8	13.0	10.0	17.5	18.5	37.0
ASC10-R3/8-O	10	R3/8	30.3	19.9	41.6	46.3	41.3	11.1	19.0	19.0×21.0	16.0	13.0	17.5	22.6	65.0
ASC10-R3/8-I	10	R3/8	30.3	19.9	41.6	46.3	41.3	11.1	19.0	19.0×21.0	16.0	13.0	17.5	22.6	65.0
ASC10-R1/2-O	10	R1/2	32.4	24.5	46.0	54.5	49.5	14.4	19.0	24.0×26.0	20.0	16.0	17.5	27.4	109.0
ASC10-R1/2-I	10	R1/2	32.4	24.5	46.0	54.5	49.5	14.4	19.0	24.0×26.0	20.0	16.0	17.5	27.4	109.0
ASC12-R3/8-O	12	R3/8	37.7	19.9	49.0	46.3	41.3	11.1	20.0	19.0×21.0	16.0	13.0	20.0	22.6	67.0
ASC12-R3/8-I	12	R3/8	37.7	19.9	49.0	46.3	41.3	11.1	20.0	19.0×21.0	16.0	13.0	20.0	22.6	67.0
ASC12-R1/2-O	12	R1/2	33.7	24.5	47.4	54.5	49.5	14.4	20.0	24.0×26.0	20.0	16.0	20.0	27.4	111.0
ASC12-R1/2-I	12	R1/2	33.7	24.5	47.4	54.5	49.5	14.4	20.0	24.0×26.0	20.0	16.0	20.0	27.4	111.0

ユニバーサルタイプ

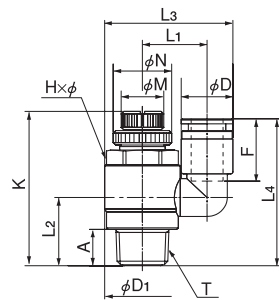

●ミリサイズ

品番	適用チューブ外径 (mm)	Tねじサイズ (M,R)	L <sub>1</sub> (mm)	L <sub>2</sub> (mm)	L <sub>3</sub> (mm)	L <sub>4</sub> (mm)	K		A (mm)	Fチューブ挿入長さ (mm)	H×φ二面幅 (mm)	N (mm)	M (mm)	D (mm)	D <sub>1</sub> (mm)	質量 (g)
							全開 (mm)	全閉 (mm)								
ASD4-M5-O	4	M5×0.8	9.9	10.1	18.5	24.5	28.6	25.8	3.4	11.0	8.0×9.0	8.0	5.0	8.0	9.6	8.0
ASD4-M5-I	4	M5×0.8	9.9	10.1	18.5	24.5	28.6	25.8	3.4	11.0	8.0×9.0	8.0	5.0	8.0	9.6	8.0
ASD4-R1/8-O	4	R1/8	12.2	13.7	23.1	28.0	36.0	31.0	7.3	11.0	12.0×13.5	11.0	8.0	8.0	14.2	18.0
ASD4-R1/8-I	4	R1/8	12.2	13.7	23.1	28.0	36.0	31.0	7.3	11.0	12.0×13.5	11.0	8.0	8.0	14.2	18.0
ASD6-M5-O	6	M5×0.8	9.9	10.1	19.5	25.9	28.6	25.8	3.4	12.0	8.0×9.0	8.0	5.0	10.0	9.6	8.0
ASD6-M5-I	6	M5×0.8	9.9	10.1	19.5	25.9	28.6	25.8	3.4	12.0	8.0×9.0	8.0	5.0	10.0	9.6	8.0
ASD6-R1/8-O	6	R1/8	12.2	13.7	24.1	29.4	36.0	31.0	7.3	12.0	12.0×13.5	11.0	8.0	10.0	14.2	19.0
ASD6-R1/8-I	6	R1/8	12.2	13.7	24.1	29.4	36.0	31.0	7.3	12.0	12.0×13.5	11.0	8.0	10.0	14.2	19.0
ASD6-R1/4-O	6	R1/4	14.3	17.1	28.4	32.9	40.3	35.3	10.8	12.0	14.0×15.8	13.0	10.0	10.0	18.5	32.0
ASD6-R1/4-I	6	R1/4	14.3	17.1	28.4	32.9	40.3	35.3	10.8	12.0	14.0×15.8	13.0	10.0	10.0	18.5	32.0
ASD8-R1/8-O	8	R1/8	16.1	14.4	30.5	35.1	36.0	31.0	7.3	16.0	12.0×13.5	11.0	8.0	14.6	14.2	22.0
ASD8-R1/8-I	8	R1/8	16.1	14.4	30.5	35.1	36.0	31.0	7.3	16.0	12.0×13.5	11.0	8.0	14.6	14.2	22.0
ASD8-R1/4-O	8	R1/4	18.2	18.0	34.8	38.7	40.3	35.3	10.8	16.0	14.0×15.8	13.0	10.0	14.6	18.5	36.0
ASD8-R1/4-I	8	R1/4	18.2	18.0	34.8	38.7	40.3	35.3	10.8	16.0	14.0×15.8	13.0	10.0	14.6	18.5	36.0
ASD8-R3/8-O	8	R3/8	20.3	18.7	38.9	39.4	46.3	41.3	11.1	16.0	19.0×21.0	16.0	13.0	14.6	22.6	64.0
ASD8-R3/8-I	8	R3/8	20.3	18.7	38.9	39.4	46.3	41.3	11.1	16.0	19.0×21.0	16.0	13.0	14.6	22.6	64.0
ASD10-R1/4-O	10	R1/4	18.2	18.0	36.2	42.6	40.3	35.3	10.8	19.0	14.0×15.8	13.0	10.0	17.5	18.5	38.0
ASD10-R1/4-I	10	R1/4	18.2	18.0	36.2	42.6	40.3	35.3	10.8	19.0	14.0×15.8	13.0	10.0	17.5	18.5	38.0
ASD10-R3/8-O	10	R3/8	20.3	18.7	40.3	43.3	46.3	41.3	11.1	19.0	19.0×21.0	16.0	13.0	17.5	22.6	66.0
ASD10-R3/8-I	10	R3/8	20.3	18.7	40.3	43.3	46.3	41.3	11.1	19.0	19.0×21.0	16.0	13.0	17.5	22.6	66.0

チューブ

クリップ

加工チューブ

プッシュダウン

クイックシール

クリップ継手

竹のこ継手

制御切替・着脱

治具・工具

技術資料

参考資料