

SLIDE & CUT AIR CUTTERS

ME Type

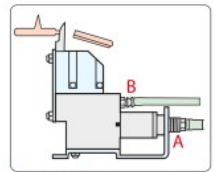

ML Type

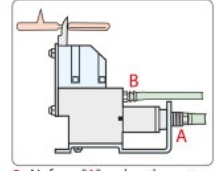
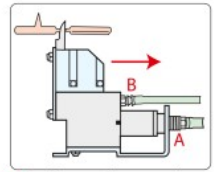
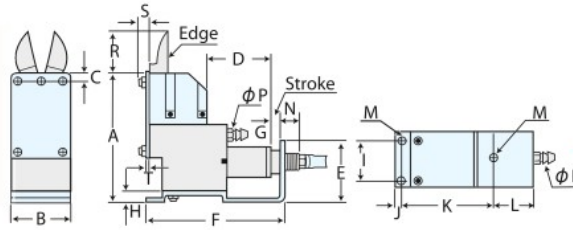
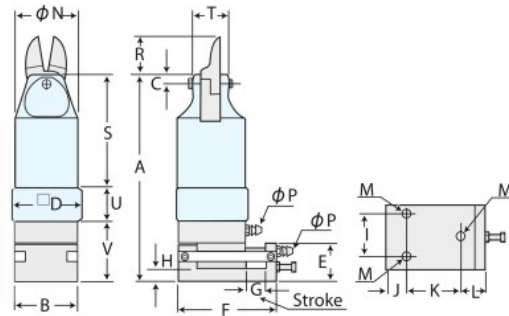

ME type specification

Model (less blade)	Weight (g)	Air consumption (cm ³ /stroke)	Air pressure (MPa)	Blade	Plastic (φmm)	Dimensions (mm)																			
						A	B	C	D	E	F	G	H	I	J	K	L	M	N	P	R	S	T	U	V
ME3	170	16	0.4~0.5	F10E,F10EK	1.0	77.2	20	8	33	34.2	71.2	3	6.2	14	2.5	50	18.7	M3	12.1	4	21	3.3	2	-	-
ME5	290	32	0.4~0.5	F1E,F1EK	1.2	79.2	29	9	30	31.2	76.2	3	6.2	22	4	50	22.2	M3	12.1	4	21	4	2	-	-
ME10	540	74	0.4~0.5	F3E,F3EK	2.5	102.2	35	10	39	42.2	88.2	3	6.2	26	5	50	33.2	M3	13	4	21	4	2	-	-
ME20	810	138	0.5~0.6	F5E,F5EK	4.5	116.2	44	13	42	48.2	103.2	5	6.2	34	5	85	13.2	M4	13	4	27	2.3	2	-	-
ME30	1,490	272	0.5~0.6	F9E,F9EK	5.0	149.2	56	15	51	64.2	127.2	5	6.2	40	7	85	35.2	M4	13	4	50	3.3	3	-	-

ML type specification

Model (less blade)	Weight (g)	Air consumption (cm ³ /stroke)	Air pressure (MPa)	Blade	Plastic (φmm)	Dimensions (mm)																			
						A	B	C	D	E	F	G	H	I	J	K	L	M	N	P	R	S	T	U	V
ML10	340	117	0.4~0.5	F3S	4.0	128	35	7	36	31	63	10	8	26	11	31	21	M3	35	4	19	71	18	16	41
ML20	500	282	0.5~0.6	F5S	7.0	143	44	9	45	31	64	10	8	26	11	36	17	M4	44	4	26	79	24	23	41
ML30	870	646	0.5~0.6	F9PS	10.0	184	55	15	56	33	76	10	8	26	14	38	24	M4	55	4	50	123	34	18	43

MG Type

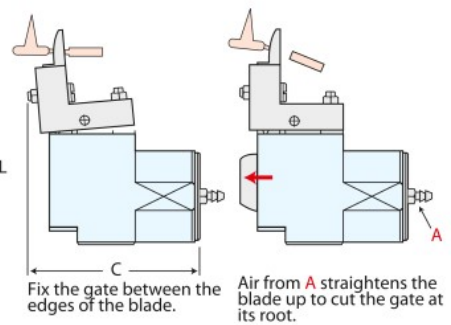
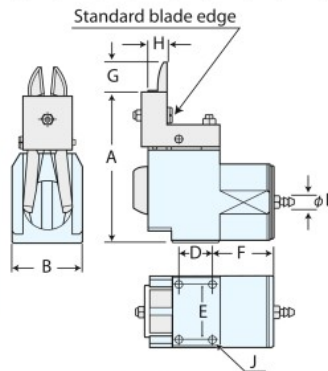

MG type specification

Model (less blade)	Weight (g)	Air consumption (cm ³ /stroke)	Air pressure (MPa)	Blade	Plastic (φmm)	Dimensions (mm)									
						A	B	C	D	E	F	G	H	J	L
MG3	80	21	0.4~0.5	FG10,FG10K	2.0	50	20	60	16	14	25	15	7	M3	4
MG10	230	70	0.4~0.5	FG3,FG3K	4.0	73	35	73	20	27	29	17.5	9	M3	4
MG20	420	213	0.5~0.6	FG5,FG5K	6.0	95	46	89	21	36	39	19	12	M4	4

(mm)					(mm)				F-E, F-S, FG-		F-EK, FG-K		F-K Type Blade	
Blade	a	b	c	d	Blade	a	c	d	a	b	a	b	d	Edge
F10E, F10EK	24	13	3.5	7	FG10	24	4	7						
F1E, F1EK	24	12	5.5	7	FG10K	24	4	7						
F3E, F3EK	27	13	7	9	FG3	27	7	9						
F5E, F5EK	35	18	9	12	FG3K	27	7	9						
F9E, F9EK	65	39	15	17	FG5	34	8	12						
F3S	27	13	5	9	FG5K	34	8	12						
F5S	35	16	9~10	12										
F9PS	65	37	16	17										