

FBN100B

● Order No. Example

FBN100B 12 D30

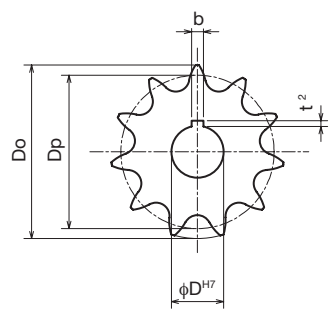
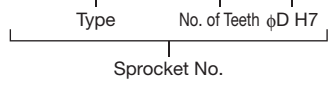

- Chain No.100
- Chain Pitch (P)31.75mm
- Roller Link Inner Width (W)19.05mm
- Roller Outside Diameter (Dr)19.05mm
- Tooth Width (T)17.6 mm

Type	No. of Teeth	Outer Diameter Do	Pitch Diameter Dp	Boss Diameter BD	Boss Length BL	a	Weight kg	φD ^{H7}	¥
FBN 100B	10	117	102.75	65	50	16	1.90	25 28 30	
	11	127	112.70	75	50	16	2.30	25 28 30	
	12	138	122.67	86	50	16	2.90	25 28 30	
	13	148	132.67	94	50	16	3.10	25 28 30	
	14	158	142.68	98	50	16	3.60	25 28 30 32 35 38 40	
	15	168	152.71	98	50	16	4.20	32 35 38 40 42 45 48 50	
	16	179	162.74	98	50	16	4.60	38 45 50	
	17	189	172.79	107	50	16	5.30	38 45 50	
	18	199	182.84	107	50	16	5.70	38 45 50	
	19	209	192.90	107	50	16	6.10	38 45 50	
	20	220	202.96	107	50	16	6.50	38 45 50	
21	230	213.03	107	50	16	7.00	45 50		