

Possible Front / Reverse R-Chamfering and C-Chamfering process !

- Reverse and Front Chamfering process ensured by changing insert
- ※ Mini R is for front only
- 8 corners of inserts can be usable.
- ※ RR25-48N is 4 corners only

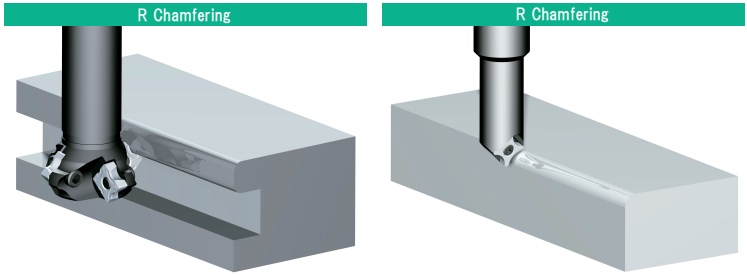

1 Ryanmencut-R (RR16-30S/RR25-40S)

2Blade 4Blade

R1~R5

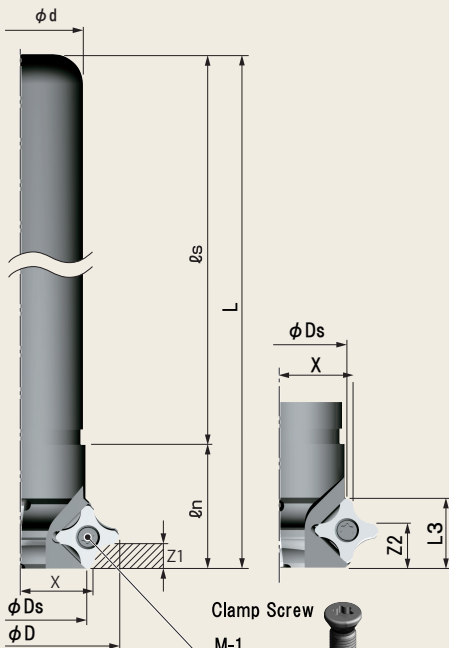

Clamp Screw M-1

Wrench MA-1

2 Ryanmencut-R (RR25-48N)

4Blade

R0.5~R5

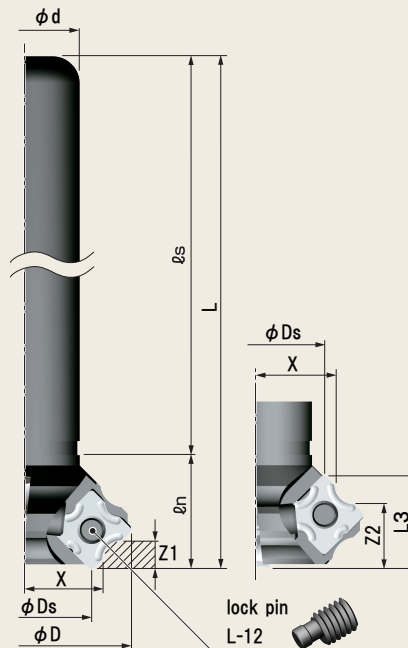

lock pin L-12

Wrench K-4

3 Mini-R (R1~R5)

1Blade

R1~R5

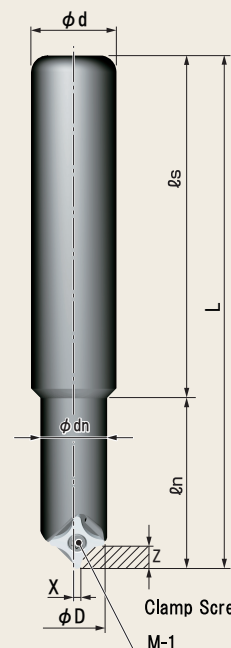

Clamp Screw M-1

Wrench MA-1

Body

Product Name	Model. No.	Fig.	blades	Dimensions (mm)								Inserts
				ϕD	ϕD_s	ϕd	ϕdn	L	ϕs	ϕn	L3	
Ryanmencut-R	RR16-30S-4R	①	2	30	17.9	16		200	175	25	16	SNEQ090308 / S32MOZ / S32GUR
	RR16-30S-5R	①	2	30	17.9	16		200	175	25	16	SNEQ090308 / S32MOZ / S32GUR
	RR25-40S-4R	①	4	40	27.8	25		200	175	25	16	SNEQ090308 / S32MOZ / S32GUR
	RR25-40S-5R	①	4	40	27.8	25		200	175	25	16	SNEQ090308 / S32MOZ / S32GUR
	RR25-48N	②	4	48	31.3	25		200	175	25	20.5	N43GXR / N43MOZ / N43GUR
Mini-R	MR20-16S	③	1	16		20	15.6	120	80	40		SNEQ090308 / S32MOZ / S32GUR

※ Insert is not supplied as standard accessory. Please order separately.
 ※ Lock pin, clamp screw, and wrench are supplied standard accessories

SNEQ090308- □ The RM, Please use.
 SNEQ090308- □ RY, You can not use.

Cutting Conditions

Ryanmencut-R(RR16-30S-RR25-40S) / Mini-R SNEQ090308 / S32MOZ / S32GUR		
Material	Feed per blade (fz)	Cutting speed (m/min)
General Steel	0.05~0.2	100~150
Alloy Steel	0.05~0.2	100~150
Stainless Steel	0.05~0.2	80~120
Aluminum, Resin, Brass	0.08~0.25	150~400
Cast Steel	0.05~0.2	100~150

Ryanmencut-R(RR25-48N) N43GXR / N43MOZ / N43GUR					
Material	Material Model	NK2001	NK1010	NK2020	NK6060
	Feed per blade (fz)	Cutting speed (m/min)			
General Steel	0.1~0.2	100~250		100~200	
Alloy Steel	0.1~0.2	100~250		100~200	150~200
Stainless Steel	0.1~0.2			80~160	150~200
Aluminum, Resin, Brass	0.1~0.3		150~300	150~300	
Cast Steel	0.1~0.3	80~150 ※FCD	80~150	80~150	

- According to the shape, clamp condition and volume of chamfering amount the above cutting condition will have to be adjusted. For large amount chamfering, the rate will have to be reduced
- For Stainless steel processing, please take down cut