

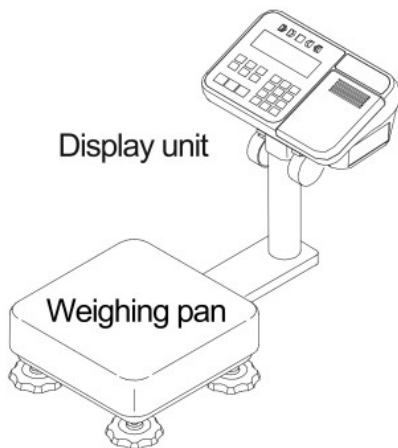

5. Package Contents

S-models

- HV-15KC
- HV-15KCP
- HW-10KC
- HW-10KCP



L-models

- | | |
|----------|-----------|
| HV-200KC | HV-200KCP |
| HW-100KC | HW-100KCP |
| HW-200KC | HW-200KCP |

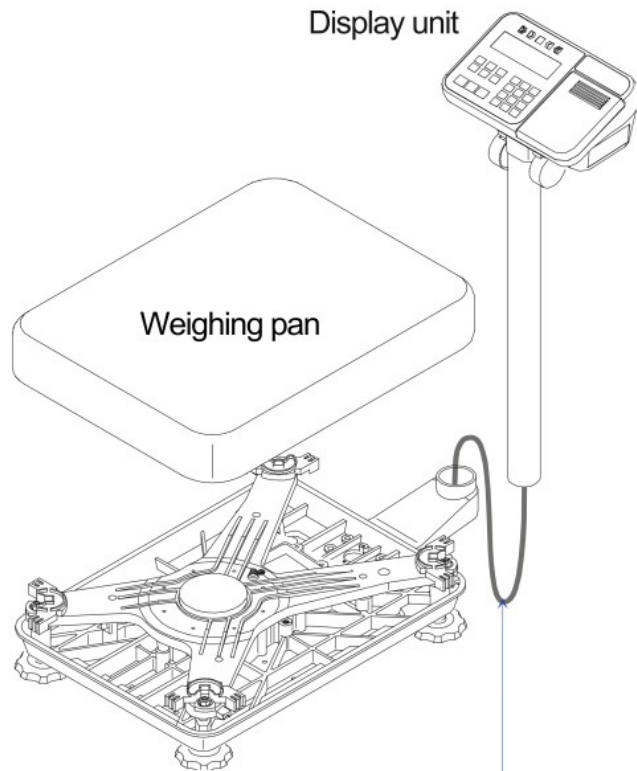

M-models

- | | |
|---------|----------|
| HV-60KC | HV-60KCP |
| HW-60KC | HW-60KCP |

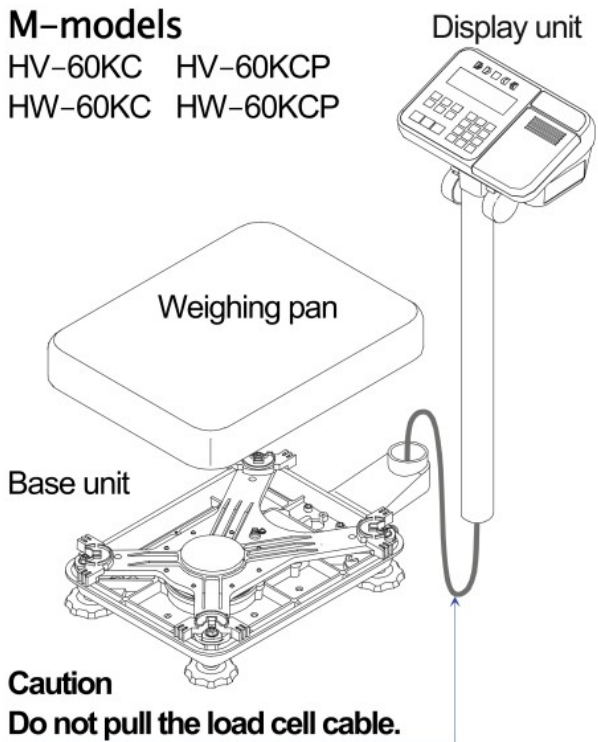

Caution
Do not pull the load cell cable.

Accessories

Accessories supplied depend on the scale.
Refer to "5.1. Accessories and Options List".

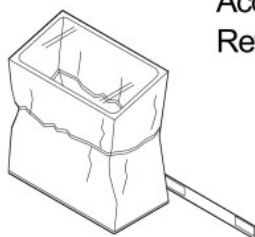

Display unit cover
AXP-3003217D



Hex wrench

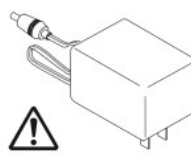

AC adapter

Please confirm that the AC adapter type is correct for your local voltage and receptacle type. The AC adapter may not be provided for some areas.